



Combined Cleaner With Gravity Table

# **METRA MGC 800**

## **USER MANUAL**



## Overview

This instruction manual is an important part of the MGC series compound cleaning machine. It is necessary information for the use, maintenance and repair of the machine. It is recommended that the user keep it properly. Before using this machine, please read this instruction manual carefully and operate it strictly in accordance with the instructions.

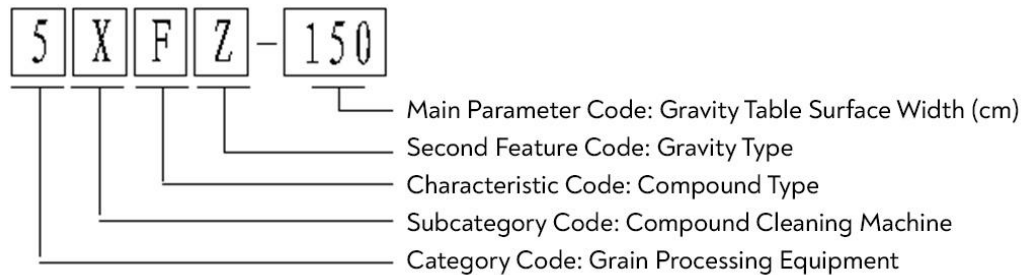

## Safety Alert Symbol

This safety alert symbol indicates important safety information. When you see this symbol, you should be alert to possible injuries, read the information below the symbol carefully, and inform other operators.

In order to better meet the production and usage requirements of our users, we have been working hard to improve our unit's products. Some changes will not be reflected in the manual one by one. The machine you received may not be completely consistent with the graphics in the user manual. We apologize for any inconvenience caused.

## 2. Purpose

The MGC series compound cleaning machine can perform wind selection, screening, and specific gravity on various crop seeds (such as wheat, rice, corn, beans, melon seeds, oilseeds, etc.) and agricultural and sideline product seeds, achieving the purpose of seed selection. It can also be used for cleaning commercial grains.

This machine is suitable for seed companies, farms and breeding departments at all levels. It is also suitable for use in grain and oil processing and agricultural and sideline products commodity grain processing and purchase departments.

This machine can only be operated, maintained and repaired by personnel who are familiar with the characteristics of the machine and have relevant knowledge of safe operation.

The manufacturer is not responsible for reduced machine reliability, machine damage or personal injury due to unauthorized modifications to the machine.

## 3. Safety Precautions

### 3.1 Electrical Safety Precautions

1. Connect the ground wire at the mark and it should be well grounded during operation.
2. Before starting the machine, an electrician must check the condition of all electrical appliances to ensure safety and reliability.
3. When the ambient humidity is high, production operations cannot be carried out to avoid accidents.
4. The power should be selected according to the product manual, and the speed of each transmission shaft specified in the product manual should not be changed.
5. The optional electrical connectors for this machine should be able to withstand the specified current and voltage, and should be equipped with overload protection devices.

## 3.2 Requirements for the machine operator (operator)

The operator should be an adult, must have received professional technical training, and have passed an assessment to obtain a qualification certificate. The entire contents of this manual should be read carefully before operation. **It is strictly prohibited for children to climb on equipment to avoid injury!**

## 3.3 Operation safety matter

### 3.3.1. Before starting the machine

① If you are using the machine for the first time, please read this instruction manual carefully and pay attention to the safety signs everywhere (see Figure 1 for the safety signs of the hoist, fan and air closer) before starting the machine.



**Note:** ① If the transport fixing plate is still installed on the machine, it must be removed and kept properly for later use.

② Check whether each fastening part is loose, if so, tighten it.

③ The working site should be flat, and use the eight screws of the machine frame to adjust the frame to a horizontal position. Adjust the height until the tires are almost free of pressure, and keep both sides consistent.

- ④ The work site should be spacious, ventilated, with sufficient escape space, and equipped with reliable fire-extinguishing equipment.
- ⑤ Before starting the machine, adjustments and maintenance should be carried out according to the instructions in the operation manual. The machine can be started only when the safety of man and machine is ensured. Material can be fed only after dry operation for 2 to 3 minutes and no abnormality occurs.
- ⑥ The selection machine should be started in a static state. When restarting, the machine should be stopped before starting again.

### 3.3.2. During work

- ① During work, the protective net and belt cover are not allowed to be removed.
- ② It is strictly forbidden to feed easily entangled objects and large impurities into the lifting feeding hopper.
- ③ When the elevator is working, it is strictly prohibited to put your hands into the feeding port.
- ④ The plug-in board under the **elevator** base should be unplugged and plugged in when it is stopped. (**Elevator optional**)



- ⑤ When the fan is working, it is strictly prohibited to stand at the fan entrance.
- ⑥ Pay attention to clearing the entanglements on the fan outlet protective net in time to avoid affecting the air volume; and it is strictly prohibited to open the protective net.
- ⑦ If the machine fails, it should be shut down immediately for maintenance. It is strictly forbidden to troubleshoot during operation.
- ⑧ When encountering a sudden power outage during operation, the power supply must be cut off in time to prevent the machine from suddenly starting after the power comes in, causing an accident.
- ⑨ After the work is completed, all materials inside the machine should be discharged from the outlet, and then run dry for 1 to 2 minutes before stopping

### 3.3.3. After shutdown

- ① The main power supply must be cut off to prevent accidents.
- ② If not used for a long time, the machine must be cleaned and stored in a dry environment.

**3.3.4. During transportation**, screw the lead screw up to the highest point and secure the screening machine body to the frame with a transportation fixing plate.

## 4. Main structure and characteristics (see Figure 2)

4.1. This machine consists of a lifting device, an air screening part, a specific gravity selection platform, and a dust removal device.

4.2. The whole machine has a compact structure, easy operation and flexible movement, and is suitable for towing all types of motor vehicles.

4.3. The whole machine is easy to clean, can effectively prevent mixing, and help ensure seed purity.

## 5. Operating instructions

### 5.1 Operating mechanism

The operating mechanism mainly includes: distribution box (see Figure 2), fan air volume adjustment handle (see Figure 2), fan air discharge adjustment (see Figure 2), fan wind direction adjustment (see Figure 2), Elevator feeding amount adjustment gate (see Figure 2).

### 5.2 Operating procedures

1. Transport the machine to the work site (for transportation methods, see the relevant section of III. Safety Precautions).
2. Adjust the screw of the machine frame to bring the frame to a horizontal position, adjust the height until the tires are almost free of pressure, and keep both sides consistent.
3. Before starting, the transportation fixing plate must be removed, check whether the connection parts of the machine are loose, and whether there are collisions, bumps, jams, etc. in the rotating parts and movable parts, and solve any problems promptly.
4. Turn on the power, turn the start switch, and check whether the steering of each part of the machine is correct.

① **Elevator**: Viewed from the barrel observation hole, the hopper should run upward. **(This item is not included in PI)**

- ② **Dust removal fan:** Viewed from the direction of the motor, the fan impeller should rotate clockwise.
- ③ Whether the direction of the fan and transmission mechanism of the specific gravity table is consistent with the rotation direction mark.
- ④ **Air closer:** Viewed from the outlet, the auger shaft should rotate clockwise.
- ⑤ **Working procedure:** Feed the crops from the elevator feeding hopper, lift them through the elevator, and enter the air screening part through the elevator conveying pipe. The materials are separated by two winds in the air screening inlet and outlet boxes. Light impurities are separated and discharged from the machine through the dust collector and impurity discharge auger; large impurities and small impurities are discharged through the impurity discharge pipe after being screened, and the remaining better materials are screened out of the grain tank by the wind and enter the specific gravity selection platform. The materials pass through The stratification is carried out by the action of wind. The lighter materials (grates, mildew) pass through the miscellaneous bucket discharge machine, and the full materials enter the screening and classifying machine (**optional**). The materials are divided into 3-5 grades according to their geometric dimensions. (User requirement) The materials will be discharged out of the machine through the respective outlets of the discharge box.
- ⑥ This machine can be used for multiple purposes and process a variety of materials. It only needs to change the specifications of the screen group (optional for the screening machine).

⑦ **The sequence of starting up and shutting down:**

The sequence of starting up is: vibrating separation screen, specific gravity selection platform, air screening part, fan, impurity discharge auger, and elevator (**optional**).

The order of shutdown is: elevator (**optional**), impurity removal auger, fan, air screening part, specific gravity selection platform, and vibrating separation screen.

## 5.3 Principles and methods of adjustment of each part

### 5.3.1. Adjustment of the feeding amount of the elevator (Optional)

The feeding amount of the elevator is determined by the feeding amount adjusting gate on the feeding bucket of the elevator. The specific position of the adjusting gate depends on the grain output of the finished product. (See Figure 2)

### 5.3.2. Principle of air screening structure.

The MGC series compound cleaning machines all adopt a new modular structure of air screening (see picture). Its main feature is that it integrates air selection and screening, with a front air screen for bulk materials and an air screen after discharging. The materials are air separated twice to effectively remove light impurities. At the same time, the materials can remove large and small impurities through the screen box, which is beneficial to improving the efficiency and quality of the specific gravity table.

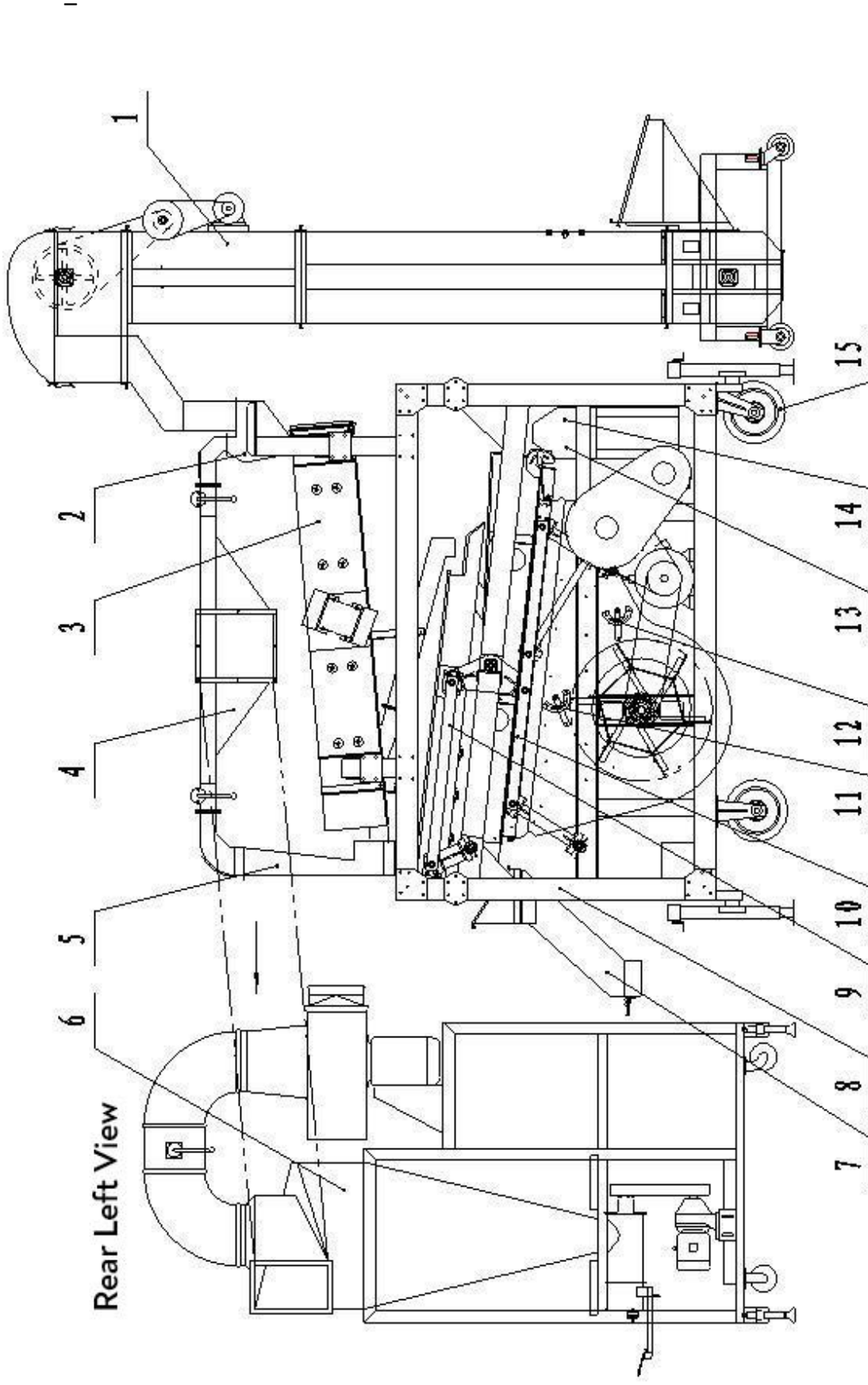

1. Mobile elevator (Optional); 2. Front air screen; 3. Screen box; 4. Connecting pipe; 5. Rear air screen; 6. Mobile dust collector; 7. Finished product outlet; 8. Big impurities outlet of screen box; 9. Rotary screen; 10. Specific gravity table; 11. Specific gravity table's air uniformity adjustment; 12. Specific gravity table's ventilation adjustment; 13. Mildew grate outlet; 14. Miscellaneous outlet of screen box; 15. Wheel.

**Figure. 2 schematic structural diagram of MGC series compound cleaner**



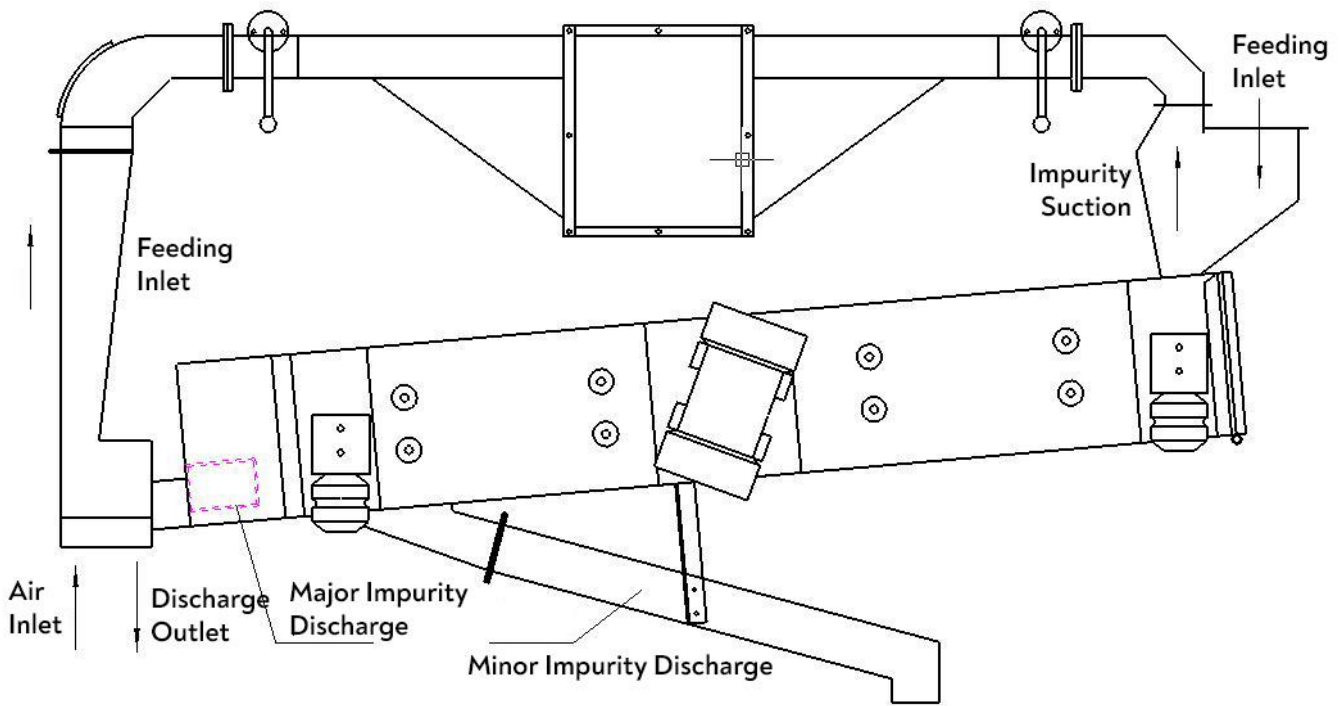

Air Separation Structure Illustration

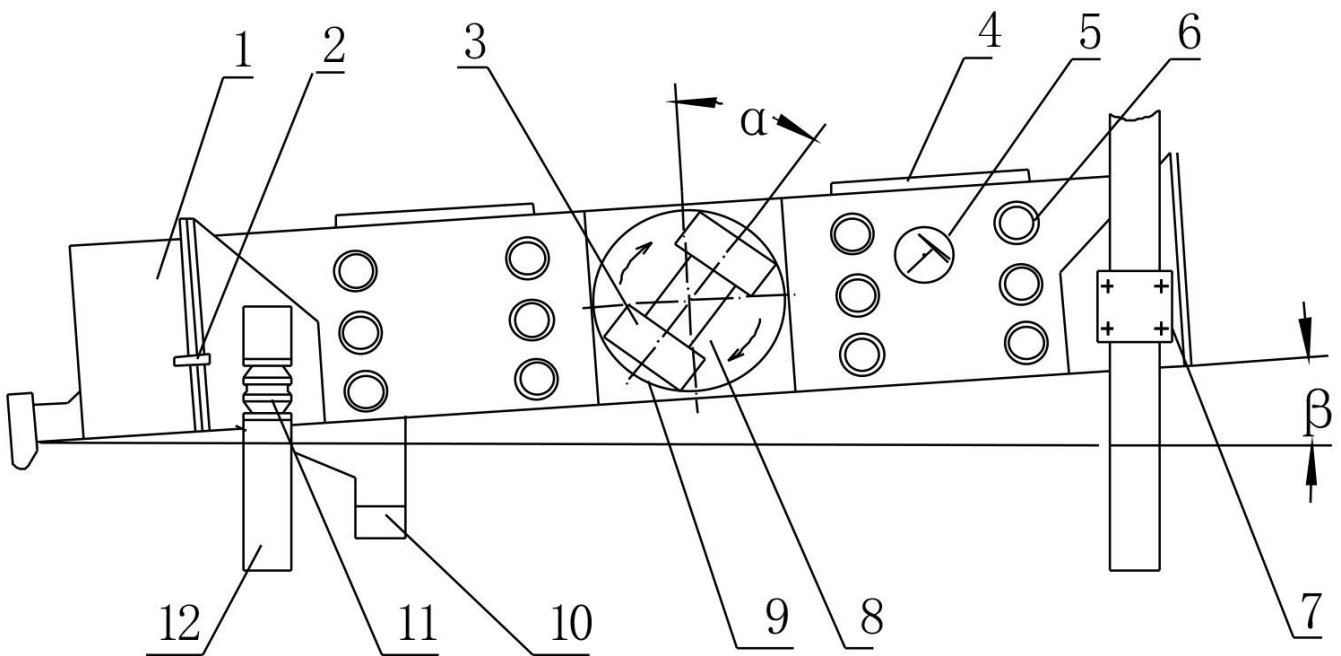

1. Discharge box; 2. Locking mechanism; 3. Vibration motor; 4. Observation window; 5. Amplitude indicator; 6. Large knob; 7. Bolt; 8. Bolt; 9. Steering wheel; 10. Small miscellaneous outlet; 11. Rubber spring; 12. Frame

**Figure 3** Schematic diagram of screening mechanism



### 5.3.3. Adjustment of vibration direction angle

Actually, it's about adjusting the angle between the axis of the vibration motor and the machine body  $\alpha$  (As shown in Figure 4), loosen the bolt (No. 8), turn the steering wheel to the desired angle, and tighten the bolt. The adjustment range is  $0^\circ$  to  $45^\circ$ , usually  $20^\circ$  to  $45^\circ$  for screening. When the machine leaves the factory, it is generally adjusted to around  $25^\circ$ .

### 5.3.4. Replace the sieve plate

Loosen the nut at the locking mechanism (see Figure 4, serial number 2) and pull out the screw. Lift the discharge box upwards to remove it. Release the large knobs on both sides of the machine on the same layer and push them inward. Then, remove the screen body, unscrew the butterfly nut that presses the screen plate on the screen body, replace the required screen plate, and follow the opposite procedure to install it.

### 5.3.5. Adjustment of amplitude (see Diagram 4)

The vibration motor is equipped with two pairs of sector-shaped eccentric blocks on the upper and lower sides. By adjusting the relative position of the two pairs of eccentric blocks, the size of the excitation force is changed, thereby changing the size of the amplitude. The amplitude can be adjusted within  $0\sim 0.25$  in ( $0\sim 6$  mm), and the maximum shall not exceed  $0.25$  in ( $6$  mm). When this machine leaves the factory, it is generally adjusted to  $0.15\sim 0.17$  in ( $4\sim 4.5$  mm). The size of the amplitude depends on the size of the overlapping surface of each pair of sector-shaped eccentric blocks. The larger the overlapping surface, the larger the amplitude, and the smaller the overlapping surface, the smaller the amplitude. Increasing the amplitude will increase productivity, while decreasing the amplitude will decrease productivity.

- ① The overlapping surfaces of the sector-shaped eccentric blocks at both ends of the same vibration motor must be the same size, and the positions of the two pairs of sector-shaped eccentric blocks must be consistent in the axial direction.
- ② The overlapping surfaces of the sector-shaped eccentric blocks at both ends of the two vibration motors of the same seed processing vehicle must be the same size.
- ③ The directions of the two vibration motors must be opposite (see Diagram 5)

### 5.3.6. Use and adjustment of signage

- ① Principle of vibration direction angle indication (see Diagram 6)

The angle between the vibration direction line of the vibration motor and the vibration table line  $\theta$  It is called the vibration direction angle, and a scale of 20-60 on the indicator panel represents the value of the vibration direction angle. When working, the centers of the four small circles on the indicator panel coincide with the dashed line formed during vibration along the vibration direction to form a straight line (i.e. the vibration direction line, as shown in Diagram 7. a). At this time, the scale value of the vibration direction angle that coincides with the straight line perpendicular to the vibration table line through the center "O" of the indicator panel and the vibration direction angle scale line on the scale panel is the value of the vibration direction angle. If the vibration direction angle is greater than the angle indicated by the indicator panel, the small circle and the dashed line cross each other (as

shown in Diagram 7 b and c). At this time, the screw at the center of the scale panel should be loosened for adjustment.

② Principle of amplitude indication (see Diagram 8)

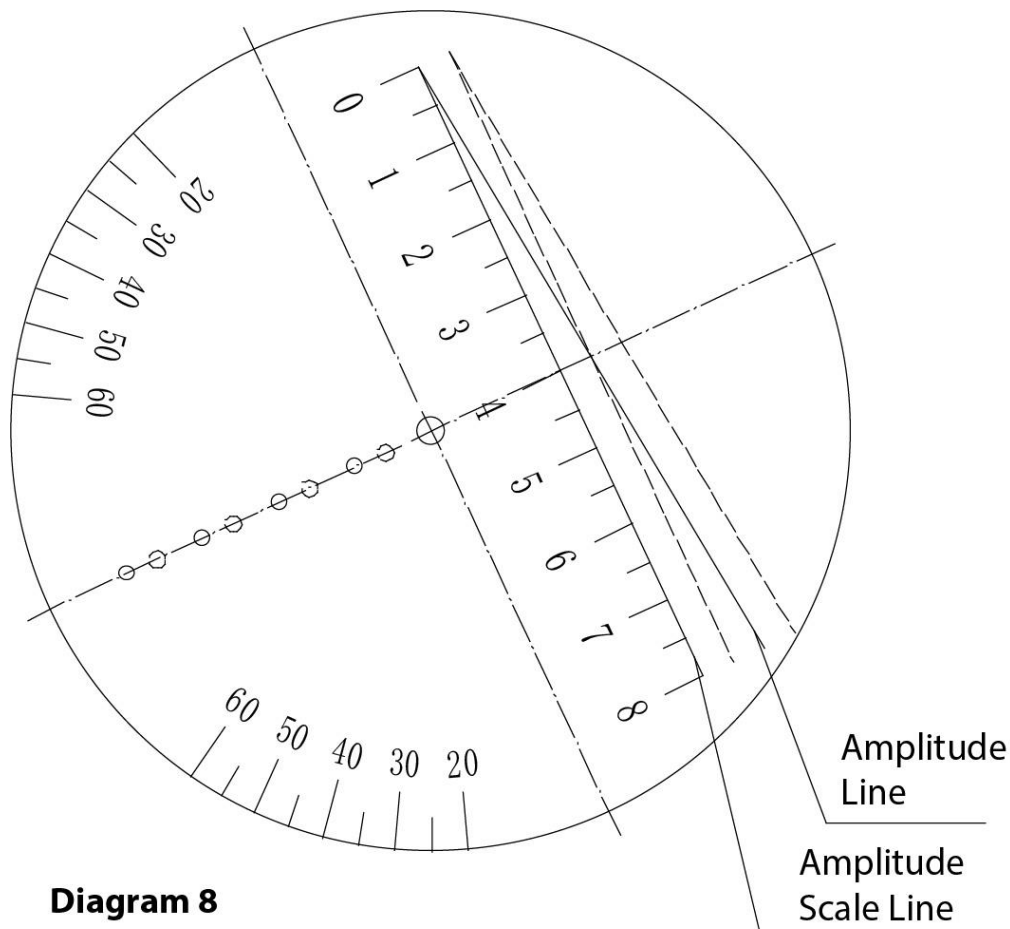
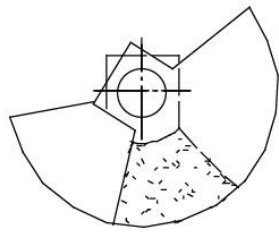

**Diagram 8**  
Amplitude Indication During Operation

The amplitude is the distance traveled by a single stroke of the machining car screening machine, which can be read from the number corresponding to the intersection of the shadow of the amplitude scale line and the amplitude line on the indicator panel.

### 5.3.7. Adjustment of wind selection air volume

Wind selection is the use of air to separate light impurities from materials and bring them into the dust collector through connecting pipes for settling and discharge, using the buoyancy generated by the lower part of the wind to filter in and out of the narrow space. The air volume adjustment handle can be used to adjust the size of the incoming air volume. If the light impurities discharged from the lower part of the dust collector are mixed with good materials, the air volume must be reduced. If there are still light impurities in the good materials after wind selection, the air volume must be increased.



a) Large Amplitude

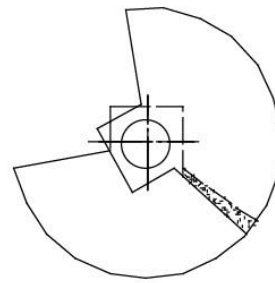

b) Small Amplitude

**Diagram 4**  
Amplitude Adjustment Illustration

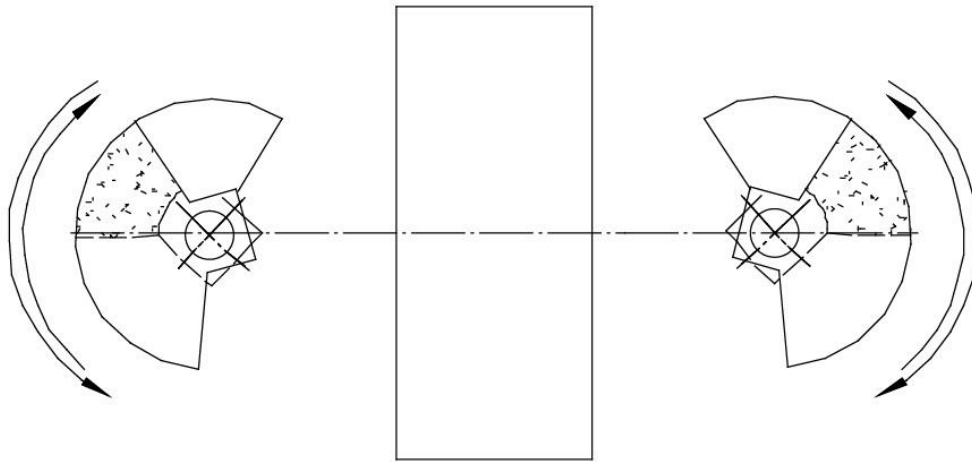

**Diagram 5**  
Amplitude Adjustment Diagram

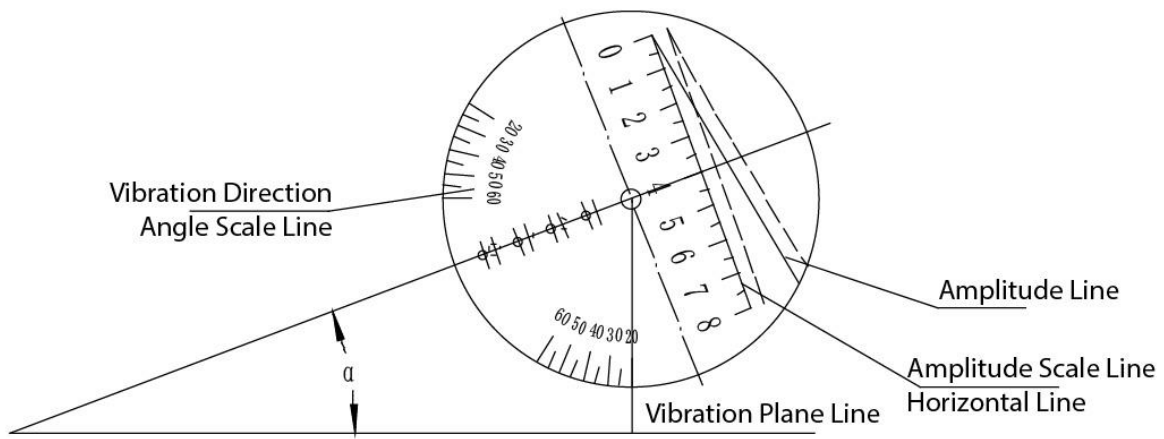

**Diagram 6**  
Vibration Direction Angle Indication Principle

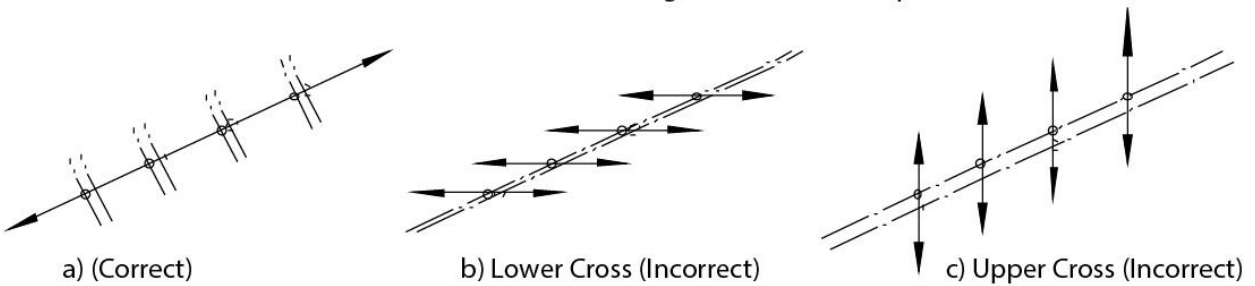
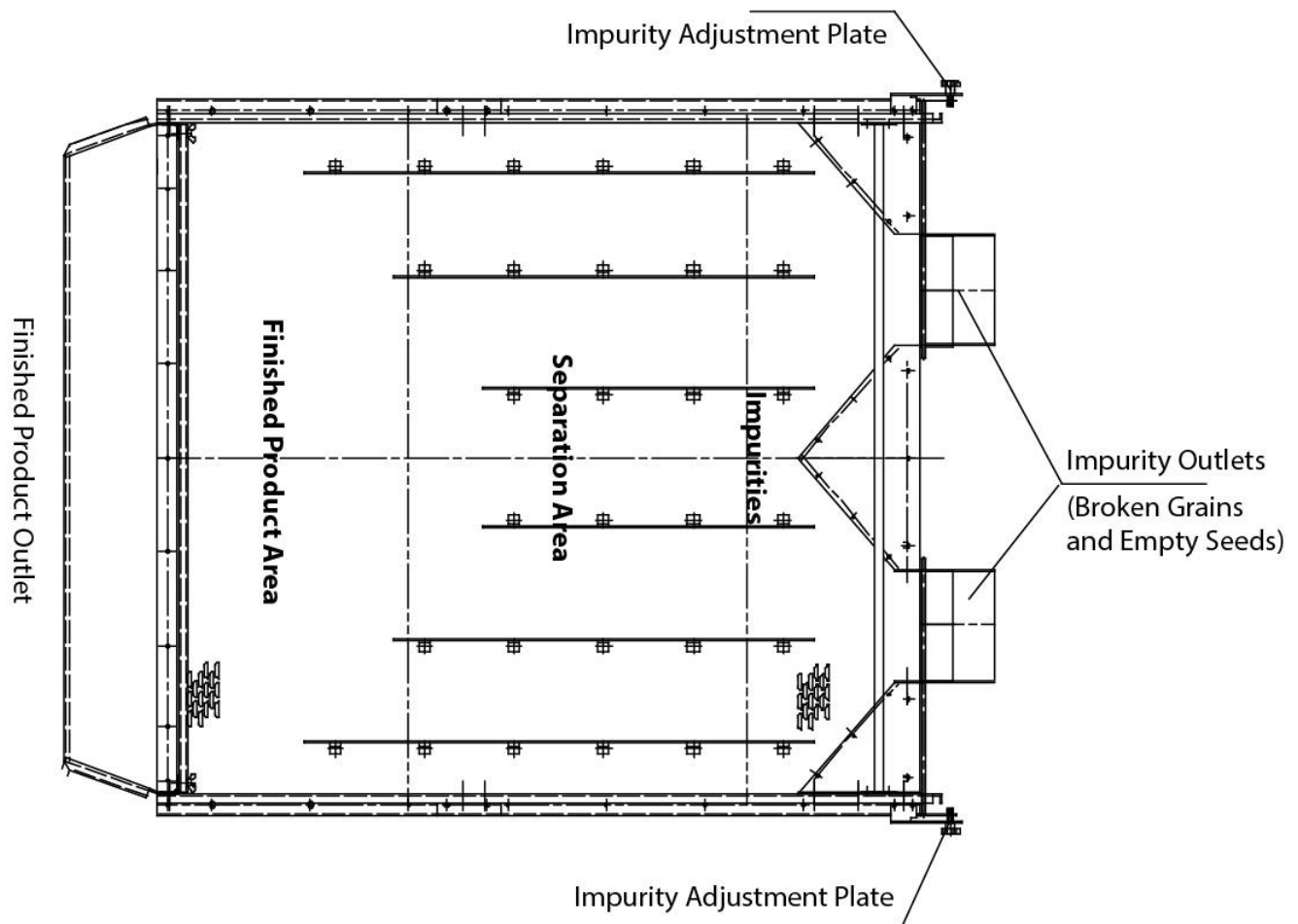

**Diagram 7**  
Scale Plate Adjustment

### 5.3.8. Adjustment of the gravity separation platform

① The adjustment of the gravity separation table is based on the selection of grain varieties. The lifting machine uniformly transports the grains to the feeding hopper according to the cleaning capacity of the machine per unit time. After removing some light impurities through wind screening, they enter the gravity table; The outlet baffle is in the closed state, and the height of the outlet baffle can be adjusted at any time according to the separation of impurities. The grain can be evenly distributed horizontally on the countertop and adjusted by adjusting the support screw.

The thickness of the outlet of the countertop containing grains is 2.35 to 3.15 in (60 to 80 mm), and the thickness of the outlet of the grain residue is 1.2 to 1.6 in (30 to 40 mm). The separation effect is better in the semi-suspended state. The cleaning effect should be determined based on grain quality and moisture content. Flexibly adjust the size of the fan vent door, the platform inlet air direction and the inclination angle of the separation table (adjusted by adjusting the screw) until the upper and lower layers of impurity-containing grains are clearly separated, and the differential reverse movement of grains and impurities is optimal.



**Diagram 9**  
Gravity Separation Platform

② Adjust the air volume of each part according to the separation of mixed grains on the specific gravity separation table. Adjust the fan air discharge volume adjustment plate (see Figure 11) and fan air direction adjustment plate (see Figure 11). The fan discharge should be adjusted based on the front half of the specific gravity separation table. The air volume is considered to be the best condition if the mixed grains move smoothly on the table, impurities are quickly separated from the grains and flow back quickly, and the clean grains are output quickly. If the movement of the mixed grains on the table is unstable, the separation and backflow of impurities is not obvious, and the output speed of the clean grain is slow, this indicates that the air volume at the front is larger, and the fan air direction adjustment plate should be adjusted so that the excess air volume flows to the rear of the specific gravity separation table, such as Although the mixed materials on the specific gravity separation table move smoothly, the impurities are poorly separated and the grain output speed is fast, which indicates that the air volume at the front is small. The fan wind direction adjustment plate should be adjusted to increase the air volume at the front of the specific gravity separation table;

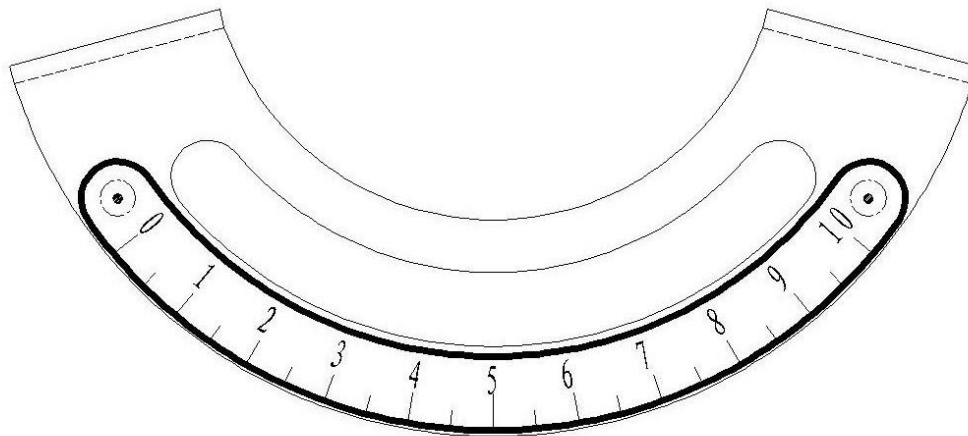

Scale Plate (Diagram 10)

Adjustment Method for Air Intake and Feed Gate				
	Material	Feed Gate Adjustment Range	Air Intake Adjustment Range	Adjustment Instructions:
1	Wheat	6.5 ~ 7.5	7	The user can adjust the gate settings according to the characteristics of the material being processed. For lighter materials, increase the feed gate and decrease the air intake gate. For heavier materials, decrease the feed gate and increase the air intake gate. This configuration ensures the optimal balance of airflow and separation quality.
2	Corn	6.5 ~ 7.5	8	
3	Soybeans	6.5 ~ 7.5	6.5	
4	Sorghum	6.5 ~ 7.5	6.5	
5	Oats	6.5 ~ 7.5	6.5	
6	Beans	6 ~ 7	9	
7	Sesame	8 ~ 9	6	

Figure. 11

## 7. Screen specifications and wearing parts

7.1. The user provides us with the screen hole specifications, and we are responsible for the preparation.

7.2. List of wearing parts:

Model	Name of spare part	Specifications
SGC-800	Observation lenses	Glass $\phi$ 112
	UCF205 with seat bearing	GB/T7810-1987
	Elevator V-belt	A1016 A1800
	Elevator bucket	SB1613
	Gravity table fan triangular belt	B-1700
	External spherical ball bearing UELFU208	(Eccentric sleeve SA208)
	Eccentric drive V-belt for specific gravity table	B-1600
	External spherical ball bearing UELFU208	(Eccentric sleeve SA208)
	Self-aligning ball bearing 1215	GB/T7810-1987
	Rubber sleeve	Rubber $\phi$ 64
	Nylon sleeve	Nylon $\phi$ 42
	(Vibration separation screen triangular belt)	B-1499
	(Vibration separation screen slider bearing)	UKKH210
	(Vibration separation screen stand bearing)	UKPH207
Dust collector discharge stirring dragon triangular belt	A-700	



## 8. Maintenance, care and repair

### 8.1 Maintenance and repair

1. Under continuous working conditions, the vibration motor, fan motor, elevator motor, shelling and awn removal machine motor, and air closer motor must be minor repaired every two months and overhauled once a year. Under the condition of intermittent work, the intervals between minor repairs and major repairs can be controlled by yourself.
2. Regularly clean dust, dirt and other impurities inside the fan and gas delivery pipe to prevent rust.
3. Add lubricating oil to each oil cup or grease nozzle once per shift.
4. After each production season, lubricating oil or grease needs to be added to each rotating part or bearing seat.
5. When not in use, the machine should be placed in a windproof, rainproof, and sunproof place, and the running wheels should be lifted off the ground using the screw.
6. Regularly check whether the traveling wheel connecting bolts are loose and tighten them before moving the equipment.

### 8.2 Common faults and troubleshooting

No.	faults	reason	troubleshooting	
2	Impurities from fan	seriously blocked of impurities pipe	clean	
		Too large air volume of fan	Adjust air door baffle	
3	Good seeds flow out from impurities pipe	Too large air volume of fan	Adjust air door baffle	
4	Good seeds with light impurities	(opposite of 3)	(opposite of 3)	
5	The material flow rate in the sieve box is low (it is adjusted reversely when the material flow rate in the sieve box is high).	The inclination angle of the sieve box is small	Stop the machine and raise the two supporting angles at the front	It has been adjusted before leaving the factory. This adjustment is generally not required.
		The included angle between the axis of the vibration motor and the horizontal direction is not appropriate.	Stop the machine and cut off the power, adjust the angle appropriately.	
		The amplitude of the vibration motor is small	Stop the machine and cut off the power, open the upper and lower covers of the two vibration motor bodies, and increase the overlapping surface area of the sector-shaped eccentric block.	
		The frame is not in a horizontal position	Adjust the screw to make the frame level	

6	Mixing of materials occurs at one or several places at the discharge port	One or several layers of screens are damaged	Replace or repair screens
		Screen clogged	
		The screen size is not suitable.	Replace screens
7	The motors all rotate in reverse	Main power supply is reversed	Swap any two terminals of the external power supply