



OPERATING MANUAL
GRAIN CLEANER METRA ADS



CONTENTS

Introduction	3
1. Purpose	4
2. Basic Technical Specifications	5
3. Configuration	6
4. Distinctiv e Features	6
5. Operation	7
6. Labeling	7
7. Safety Regulations	8
8. Mounting	9
9. Adjustm ent Procedure	10
10. Capacity Calculation	12
11. Maintenance	13
12. Transportation	14
Storage	17
Repair	18
Movement in Operation	19
Annexes	20

INTRODUCTION

This document is an Operating Manual (Certificate) supplied with each Metra Grain Cleaner (other names are: Metra Separator And Seed Grader, Metra Aspiration Fractionator).

It is for familiarizing oneself with the equipment, the safety operation, and acquisition of operating skills. Each person must study this Certificate before installing or operating the Metra ADS Grain Cleaner.

This document contains information about the Metra ADS Grain cleaner, its technical specification, safety instructions, information about the manufacturer and warranty conditions.

during the entire operation period, the user must keep a record of the operation quality of the product, taking notes and recording in the appropriate section of the Certificate.

The manufacturer reserves the right to change the design to improve the equipment. These changes may not be reflected in this Certificate.

1. PURPOSE

1.1. Purpose:

The Grain Cleaner Metra ADS is designed for cleaning and grading of all types of seeds and cereal grains, as well as any kinds of bulk material.

1.2. Operation Modes:

1. Preliminary cleaning mode;
2. Precise grading mode;
3. Mixed mode (simultaneous cleaning and grading).

1.3. Mounting:

Mounting of the Metra is possible:

- on farms;
- on grain elevators as well as terminals and processing plants.

2. BASIC TECHNICAL SPECIFICATIONS

Table 1

Model	Capacity: cleaning / grading mode	Dimensions: length - width - height	Energy consumption	Power consumption	Weight
ADS-600	600 bushels in hour 15 tons in hour	90.5x27.5x94.5 in 2300x700x2400 mm	1.3 - 4.0 HP 1.0 - 3.0 kW	220V, 60Gz	820 lbs 370 kg
ADS-800	800 bushels in hour 20 tons in hour	90.5x27.5x94.5 in 2300x700x2400 mm	1.6 - 5.4 HP 1.2 - 4.0 kW	220V, 60Gz	840 lbs 380 kg
ADS-1200	1200 bushels in hour 30 tons in hour	90.5x27.5x94.5 in 2300x700x2400 mm	1.9 - 6.8 HP 1.4 - 5.0 kW	220V, 60Gz	890 lbs 400 kg
ADS-1600	1600 bushels in hour 40 tons in hour	88.4x49.2x94.5 in 2500x1250x2400 mm	3.2 - 10.3 HP 2.4 - 7.6 kW	220V, 60Gz	950 lbs 430 kg
ADS-2000	2000 bushels in hour 50 tons in hour	88.4x49.2x94.5 in 2500x1250x2400 mm	3.2 - 10.3 HP 2.4 - 7.6 kW	220V, 60Gz	995 lbs 450 kg
ADS-4000	4000 bushels in hour 100 tons in hour	122x63x118.5 in 3100x1600x3010 mm	6.5 - 20.4 HP 4.8 - 15.0 kW	480V, 60Gz	1900 lbs 860 kg
ADS-6000	6000 bushels in hour 150 tons in hour	123.2x68.9x118.9 in 3130x1750x3020 mm	7.0 - 18.0 HP 9.5 - 24.5 kW	480V, 60Gz	2010 lbs 910 kg
ADS-8000	8000 bushels in hour 200 tons in hour	123.2x68.9x118.9 in 3130x1750x3020 mm	20.4 - 40.8 HP 15.0 - 30.0 kW	480V, 60Gz	2120 lbs 960 kg
ADS-600 CDC	600 bushels in hour 15 tons in hour	189x53.3x112.2 in 4800x1355x2850 mm	1.3 - 4.0 HP 1.0 - 3.0 kW	220V, 60Gz	1655 lbs 750 kg
ADS-800 CDC	800 bushels in hour 20 tons in hour	189x53.3x112.2 in 4800x1355x2850 mm	1.6 - 5.4 HP 1.2 - 4.0 kW	220V, 60Gz	1765 lbs 800 kg
ADS-1200 CDC	1200 bushels in hour 30 tons in hour	189x53.3x112.2 in 4800x1355x2850 mm	1.9 - 6.8 HP 1.4 - 5.0 kW	220V, 60Gz	1920 lbs 870 kg
ADS-1600 CDC	1600 bushels in hour 40 tons in hour	204.7x64.2x116.2 in 5200x1630x2950 mm	3.2 - 10.3 HP 2.4 - 7.6 kW	220V, 60Gz	2040 lbs 925 kg
ADS-2000 CDC	2000 bushels in hour 50 tons in hour	204.7x64.2x116.2 in 5200x1630x2950 mm	3.2 - 10.3 HP 2.4 - 7.6 kW	220V, 60Gz	2075 lbs 940 kg
ADS-4000 CDC	4000 bushels in hour 100 tons in hour	252x88.6x145.7 in 6400x2250x3700 mm	6.5 - 20.4 HP 4.8 - 15.0 kW	480V, 60Gz	3440 lbs 1560 kg
ADS-6000 CDC	6000 bushels in hour 150 tons in hour	252x88.6x145.7 in 6400x2250x3700 mm	7.0 - 18.0 HP 9.5 - 24.5 kW	480V, 60Gz	3550 lbs 1610 kg
ADS-8000 CDC	8000 bushels in hour 200 tons in hour	252x88.6x145.7 in 6400x2250x3700 mm	20.4 - 40.8 HP 15.0 - 30.0 kW	480V, 60Gz	3660 lbs 1660 kg

3. CONFIGURATION

All models of the grain cleaner Metra ADS are supplied in basic configuration. If desired, the equipment can be changed with a new contract.

Complete set:

1. Grain cleaner Metra ADS.
2. Certificate.

4. DISTINCTIVE FEATURES

4.1. Overall design:

The Metra Grain Cleaner are equipment for separating bulk materials on fractions within the airflow generated inside the separation chamber.

Application of the impeller in the Metra Grain Cleaner provides the following advantages:

- * Minimal airflow power losses;
- * Decrease of power consumption by 3-4 times or more;
- * Increased functionality of the equipment;
- * Increased service life of motor.

The frequency converter (VFD, Variable Frequency Drive) is incorporated for motor speed control. This allows precise air flow adjustment so that the Metra Grain Cleaner is accurately tuned for operation with any material.

The separation chamber is equipped with baffles for the output trays. Using the baffles, the operator can easily direct the grain flow to the desired trays and improve the quality of grading by means of precise settings.

4.2. Models with CDC (Cyclone Dust Collector):

The grain cleaner Metra ADS models with CDC (Cyclone Dust Collector) provide air cleaning during operation. Impurities, dust, chaff and non-grain waste is removed through the special waste trays.

The air is flown inside the Metra Grain Cleaner in a closed circuit, thus the air is purified effectively inside the system. No additional cyclones or any other aspiration equipment is required.

5. OPERATION

- The Metra Grain Cleaner grades source material in the airflow.
- Initial grading is performed due to differences of weight and windage properties.
- Heavy impurities, like stones, are separated into the first output tray.
- Seeds of the highest sowing quality (the most viable, with the highest germination capacity) are directed into the second and third output trays.
- Commodity seeds are directed into the fourth and fifth output trays.
- The sixth and seventh output trays are collecting feed (forage) seeds.
- The dust, chaff and other light impurities are blown out with the airflow outside the Metra.
- Separator or directed through the CDC (Cyclone Dust Collector) into the special waste trays.

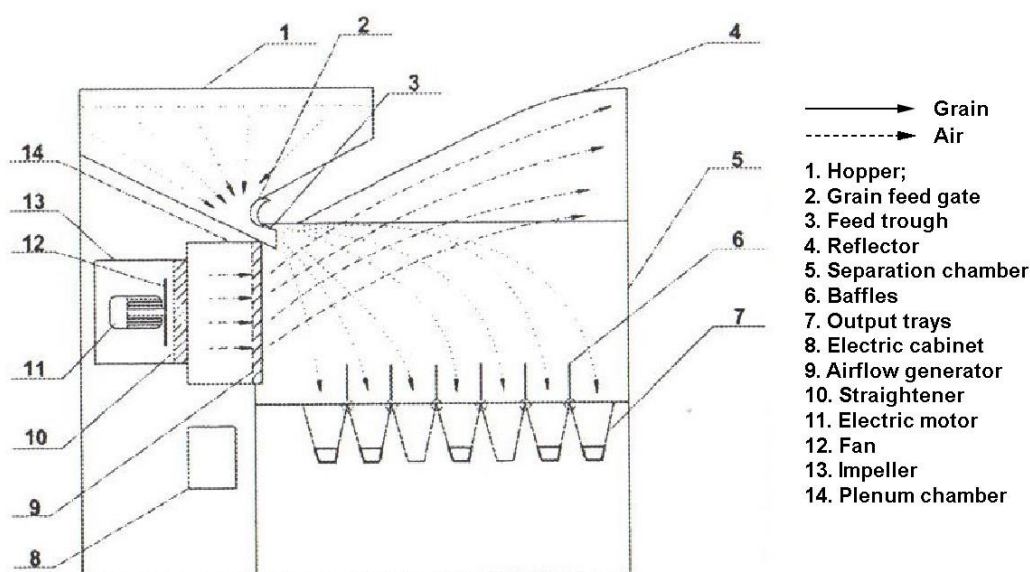

6. LABELING

6.1. The Metra Grain Cleaner labeling:

The outer surface of each Metra Grain Cleaner should have an attached labeled plate with the corresponding text:

1. Name of the manufacturer;
2. Model and type of the Metra Grain Cleaner;
3. Designation of technical specifications (technical conditions) the Metra Separator corresponds to;
4. Serial number of the Metra Grain Cleaner;
5. Date (Month and Year) of manufacture.

6.2. Control labeling:

Controls of the Metra Grain Cleaner operation, the buttons/switches are the following:

- 'ON'
- 'OFF'
- 'START'
- 'STOP'
- 'ROTATION DIRECTION'
- 'SPEED'
- 'EMERGENCY STOP'.

7. SAFETY REGULATIONS

Before operating the Metra Grain Cleaner, the user must comply with the following safety requirements:

Check the reliability of the connection of visible ground (protective earth) conductors to the equipment, availability and reliability of grounding contacts fastening, plugs, sockets, and connectors;

Total resistance of earthing devices: all re-grounding neutral conductor transmission line shall not exceed 10 Ohms.

The construction of connector plugs must be so that they cannot be plugged in with a higher nominal voltage than the rated Metra Grain Cleaner voltage. Prior to connecting, make sure that suitable voltage is applied according to the connector base diagram. Avoid pulling and twisting of cables or power cords when connecting the equipment. Do not subject them to mechanical stress & do not put loads on them. Avoid direct contact between the wire and cable with hot, wet, oily surfaces or objects.

When working with treated seed it is necessary to conduct medical examinations and provide staff with personal protective equipment.

While operating the Metra Grain Cleaner without CDC (Cyclone Dust Collector) the user should wear dust-proof goggles and a respirator.

CAUTION!

Mounting (dismounting) of the Metra Grain Cleaner is to be performed only when equipment is de-energized.

Mounting (dismounting) of the Metra Grain Cleaner is to be performed only on a flat stable surface, while following all the mounting (dismounting) rules and requirements.

FORBIDDEN!

- **Do not operate the Metra Grain Cleaner without reading the operating instructions.**
- **Do not operate the Metra Grain Cleaner without grounding.**
- **Do not operate the Metra Grain Cleaner when the power supply voltage is non-compliant with electrical installation code requirements, namely for voltage 220V + - 10%.**
- **Do not operate the Metra Grain Cleaner without any protective elements of the rotating parts.**
- **Do not open units and blocks under voltage.**
- **Do not make changes in the program of the frequency converter.**
- **Do not operate the Metra Grain Cleaner in places where precipitation may fall on it (rain, snow, fog, dew etc.).**

8. MOUNTING

See Annex 1 during mounting.

8.1. Recommendations for the Metra Grain Cleaner mounting:

When mounting the Metra Grain Cleaner, the fitter needs to have at least 1200 mm (4 ft) of free space from all sides to provide ease of maintenance.

8.2. The Metra Grain Cleaner mounting procedure before operation:

Mount the Metra Grain Cleaner to the location for further operation.

1. When mounting the Metra Grain Cleaner with the removed hopper and reflector, mount them in place by twisting the screws.
2. If the Metra Grain Cleaner is supplied with a tap for light fractions, then install the outlet and secure it with bolts to the reflector.
3. Install feed and discharge conveyor so as to provide a continuous separation process (if necessary, the conveyors will be completed as option).

8.3. Connection to power supply:

The Metra Grain Cleaner connection to power mains must be performed by a qualified electrician having electrical safety access.

- Connect the ground to the general grounding circuit in the building.
- Connect the power cable to the 220V network according to Table 1.
- Connections are made by cable with cross-section not less than the cross section shown in Table 2, which meets the requirements of electrical mounting rules, taking into account losses in the power supply line.

Table 2

Model	Rated power, kW / hp	Cable cross-section, mm ² Copper	Cable length, m/ft
ADS-600 ADS-600 CDC	2.2 / 3	3x2.5	up to 50/165
ADS-800 ADS-800 CDC	3 / 4	3x2.5	up to 50/165
ADS-1200 ADS-1200 CDC	4 / 5	3x2.5	up to 50/165
ADS-1600 ADS-1600 CDC	5.5 / 7	3x4	up to 50/165
ADS-2000 ADS-2000 CDC	6 / 9	3x4	up to 50/165
ADS-4000 ADS-4000 CDC	11 / 15	5x6	up to 50/165
ADS-6000 ADS-6000 CDC	15 / 20	5x10	up to 50/165
ADS-8000 ADS-8000 CDC	22 / 30	5x10	up to 50/165

9. ADJUSTMENT PROCEDURE

9.1. The Metra Grain Cleaner switching on:

1. Set the 'Feed Gate Control' handle to the '0' position.
2. Fill the hopper with grain to the specified level, not less than minimal level.
3. Reset the 'EMERGENCY STOP' button.
4. Move the 'POWER' knob to 'ON'. The 'POWER' indicator will light up if it is under voltage.
5. Set the 'POWER' knob to the middle position.
6. Turn on the frequency converter power, by setting the 'DIRECTION OF ROTATION' switcher in the separation or reverse mode.
7. Together with the indicator lights, the impeller motor will begin to smoothly gain speed reaching predetermined speed.
8. Turn off the Metra Grain Cleaner in reverse order.
9. Pressing the 'EMERGENCY STOP' button carries out emergency shutdown of the Metra Grain Cleaner.

Press the 'EMERGENCY STOP' button only in cases of emergency!

9.2. Operating modes settings:

Preliminary cleaning mode

1. Switch on the Metra Grain Cleaner as described above.
2. Fill the hopper with material. Ensure continuous supply of the material to the hopper. During operation the user must control the amount of the material in the hopper - it must be filled to at least 75% of its volume.
3. Set the baffles in upward position, so they are in '0' position.
4. Turn the 'Feed Gate Control' handle to open position. Adjust the 'Speed' knob to the maximum possible value, so the grain (or other clean material) is not coming out with the light impurities removal.
5. If the Metra Grain Cleaner is equipped with CDC (Cyclone Dust Collector), make sure that all connections are tight with the main Metra Grain Cleaner. Make sure that the gate duct is blocked. Restriction or partial overlapping of the CDC output tray is not allowed, as this may lead to malfunction of the Metra Grain Cleaner.

In this mode, when the Metra Grain Cleaner is properly adjusted, it's able to remove 30% to 60% of the original waste material, depending on the quality of the grain. When the Metra Grain Cleaner is operating in this mode, refined grain will be fed from all trays.

Note that when the material is very dirty, you might need to clean in several stages: first to separate good grains from the 2nd – 3rd trays, having dropped the rest of the material from the 4th – 6th trays into a common storing hopper, and then clean and grade the second time the grains from the 4th – 6th trays.

Precise grading mode

1. Switch ON the Metra Grain Cleaner as described above.
2. Fill the hopper with material. Ensure a continuous supply of the material to the hopper. During operation the user must control the amount of the material in the hopper - it must be filled to at least 75% of its volume.
3. Set the baffles in upward position, so they are in '0' position.
4. Turn the 'Feed Gate Control' handle to a position of '0.5-1'.
5. Adjust the 'Speed' knob so to receive clean grain in the 2nd-4th trays/outputs.

Properly adjusted Metra Grain Cleaner will direct:

- the stones/heavy impurities into the 1st tray;
- the heaviest and the largest grains – into the 2nd tray (premium quality, seed grains);
- slightly less heavy grains – into the 3rd (premium quality, commodity grains);
- a mixture of smaller grains and the biggest but damaged seeds should go into the 4th tray;
- broken grain, split grain, grain damaged by insects, and all sorts of impurities (fodder) – into the 5th and 6th trays.

First stage, you need to precisely grade and obtain the premium grain (the heaviest with the highest seeding quality) from the 2nd – 3rd trays, while directing the rest of the material into a common hopper. The worst grains from the 6th tray could be used as fodder (forage).

After this you can run the grain from the 4th and 5th trays once more thus increasing the amount of good grains.

In the precise grading mode the source material is also cleaned when passing through the separation chamber.

Please note: The capacity of the Metra Grain Cleaner can be increased (the amount of grain fed into the separation chamber can be increased) until the process of cleaning / grading gets worse. The extent of grading quality improvement varies for different crops, so the user determines it individually.

Recommended speed indicator readings for the airflow settings:

Table 3

Crop	Speed indicator reading
Rapeseed, sunflower seeds, buckwheat	2-3
Wheat, barley, oats	3-4
Corn	4-5
Soy beans, chickpeas, peas	5-6
Beans	6-8

The data in Table 3 are given for standard humidity level and impurity content. If these parameters exceed the norm, then the settings should be changed and selected individually.

9.3. Settings of the baffles:

If necessary, close or completely open the needed trays by turning the respective baffles. Note that when you change the angle of the tray opening with baffles, you can significantly improve the quality of grading. All trays are able to bulk material to the left and to the right side of the Metra Grain Cleaner, making it possible to prevent ingress of the 4th - 6th fractions into the best grain from the 2nd - 3rd trays.

10. CAPACITY CALCULATION

Formula for capacity calculation:

$$Q=QN*K1*K2$$

where: QN- nominal capacity, t/h;

K1, K2 - conversion factor (Table 4 and Table 5).

Conversion factor of grain cleaning capacity depending on the crop

Table 4

Crop	Bulk weight, kg / cubic meters	Factor K1	Crop	Bulk weight, kg / cubic meters	Factor K1
Beans	-	1.20	Sunflower seeds	355	0.25
Peas	800	1.00	Hummel rice	700	0.50
Wheat	760	1.00	Awed rice	700	0.40
Corn	700	1.00	Sugar-beet	300	0.40
Bread-corn	700	0.9	Millet	850	0.30
Barley	650	0.8	Rapeseed	-	0.30
Vetch oatmeal mix	-	0.75	Linseed, camelina	700	0.25
Meadow grass	-	0.04	Wheat grass	-	0.25
Buckwheat	650	0.70	Cow clover	780	0.20
Spring vetch	-	0.70	Medick	780	0.20
Oatmeal	500	0.70	Ryegrass	-	0.15
Soybean	720	0.70	Meadow fescue grass	-	0.14
Sorghum	750	0.60	Cat's-tail	700	0.12
Lentil	765	0.60	Carrot	480	0.10
Kenaph	-	0.60	Cocksfoot	-	0.09
Winter vetch	-	0.60			

Depending on the humidity level and impurity conten

Table 5

Humidity, %	Content of impurities, %	K2 Factor value
Up to 18 inclusive	5	1.0
	10	0.9
	15	0.8
Over 19 - 22	5	0.9
	10	0.8
	15	0.7
23 - 26	5	0.8
	10	0.7
	15	0.6
27 - 30	5	0.7
	10	0.6
	15	0.5

11. MAINTENANCE

The Metra Grain Cleaner cleaning:

Before sending the Metra Grain Cleaner to storage or preservation, it is necessary to perform cleaning and check fastenings of the moving parts.

When withdrawing the Metra Grain Cleaner from storage or preservation, it is necessary to remove dust and dirt deposits using a soft cloth, check the smoothness of the impeller rotation and carry out maintenance of the motor.

11.1. Quick cleaning:

- Switch on the Metra Grain Cleaner, adjust the 'Speed' knob to the maximum possible value, open the 'Feed Gate Control' handle of the hopper, open the CDC (Cyclone Dust Collector) gate.
- The Metra ADS Grain Cleaner should run in this mode for 3-5 minutes.
- Clean the waste trays, if necessary.

Quick cleaning should be made no less than once per shift.

11.2. Complete cleaning:

- Remove the cover of the CDC (Cyclone Dust Collector).
- Remove all dust and other deposits from the CDC.
- Remove the back cover of the CDC.
- Remove all deposits in the CDC.
- Clean and blow off the trays with airflow.
- Remove the sector from air duct adjacent to the impeller chamber.
- Clean and blow off the air chamber and the electric motor.
- Switch on the Metra Grain Cleaner, adjust the 'Speed' knob to the maximum possible value, open the 'Feed Gate Control' handle of the hopper, open the CDC gate. The Metra Separator should run in this mode for 3-5 minutes.
- Assemble the Metra Grain Cleaner in reverse order.

When assembling, check the tightness of all seal elements and replace them if necessary.

Complete cleaning should be performed at least every 150 hours of the Metra ADS Grain Cleaner operation.

12. TRANSPORTATION

The Metra ADS Grain Cleaner can be transported by any means of transport, according to the shipping rules.

Placing and securing of cargo is carried out in accordance with the current technical rules of cargo loading and securing.

Loading and unloading of the Metra ADS Grain Cleaner is performed in two ways: either by forklift or crane.

When using a forklift:

Put the forks into the guide positioned at the bottom of the frame.

When using a crane:

Strapping of the Metra Grain Cleaner is to be made according to scheme
(See 'Annex 1').

When transporting the Metra Grain Cleaner in covered vehicles, transportation without shipping packaging or with partial packaging which provides protection against mechanical damage is allowed.

STRONGLY FORBIDDEN!

- Do not perform the Metra Grain Cleaner strapping without traverse
- (See 'Annex 1').
- Do not perform the hopper loading and unloading using a forklift.
- Placing and securing cargo units on vehicles should provide a stable position, displacement and strikes are not allowed.

15. STORAGE

- Storage of the Metra Grain Cleaner is carried out in a dry ventilated space.
- Rainfall and foreign objects hit is not allowed.

Date		Storage conditions	Storage type	Remarks
Accepted for storage	Withdrawn from storage			

16. REPAIR

Date	Operating time since the beginning of operation period, hours	Operating time after the last repair, hours	Reason for repair	Information about repair

17. MOVEMENT IN OPERATION

Mounting date	Mounting place	Dismounting date	Operating time from the beginning of operation period, hours	Reason for dismounting	Full name and signature

Metra Grain Cleaner strapping scheme

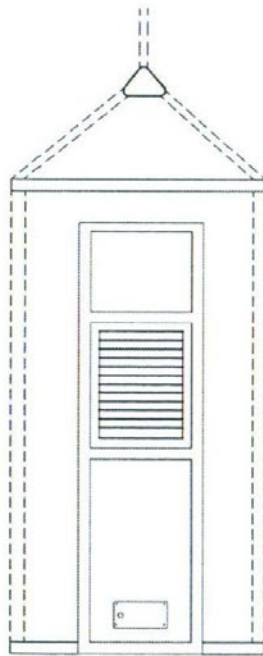
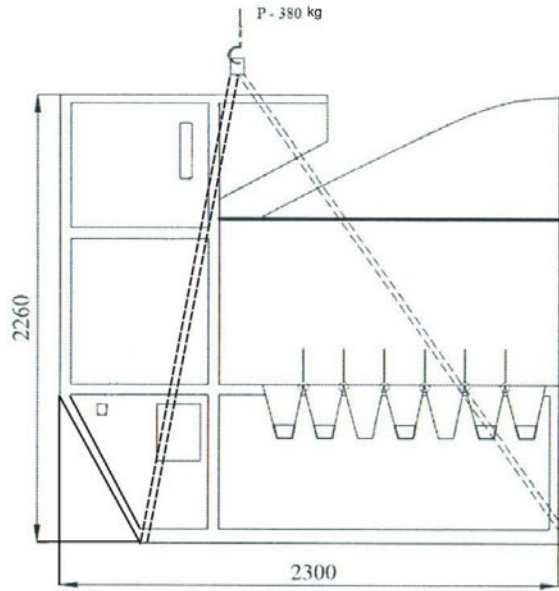



 graincleaner.com

 **+1(800)272-2045**

 info@graincleaner.com